

SPIROL[®]

SLOTTED SPRING PINS



ISO 8752
ASME B18.8.2
ASME B18.8.4M

SPIROL[®] SLOTTED SPRING PINS



SPIROL[®] Slotted spring pins manufactured to ISO 8752 (EN 28752), ASME B18.8.4M Type B (Metric), and ASME B18.8.2 (Inch) are available from stock.

- DIN 1481 is interchangeable with ISO 8752 (EN 28752) except for a variation in length tolerance.
- The ASME B18.8.2 range meets the requirement of NASM 10971 (formerly MIL-P-10971), NASM 16562 (formerly MS 16562), NAS 561, SAE J496, and SAE AS7207 (Supersedes AMS 7207 and MS 17140-17190).
- ISO 13337 (DIN 7346), lightweight Slotted Pins, are available made-to-order for volume applications.

ISO/TS 16949:2002 and ISO 9001:2000 certifications are your guarantee for consistent quality.

- ⊙ **Contract Review / Quality Planning.** A formal procedure exists for the specification and acceptance of new orders by sales, manufacturing and quality.
- ⊙ **Document / Drawing Control.** All drawings, standards and specifications are controlled through engineering.
- ⊙ **SQA Approval of Suppliers and Subcontractors** is maintained by supplier system audits and monitoring of supplier quality performance.
- ⊙ **System Audits** are carried out regularly by independent auditors with written reports submitted for management action.
- ⊙ **Calibration and Gauge Control.** All gauges are calibrated on a regular basis, traceable back to national standards. The control records are computerized.
- ⊙ **All parts are traceable** through each manufacturing process and heat treatment back to the original raw material test certificate. Each lot has a unique identification number on the packaging which should be retained by the customer and quoted in the event of any inquiry.
- ⊙ **Manufacturing Controls.** There is clear identification of job and quality status with controlled routings. Capability studies are used to verify machine and process capability; statistical process control is used for all processes, using variable and attribute data; and there are final audit checks of completed parts and stock.
- ⊙ **Non-Conforming Parts.** These are segregated with a "hold" label and quarantined pending a decision on disposal. An automated corrective action system ensures management control for quick and accurate responses to customer inquiries.

PART DESCRIPTION

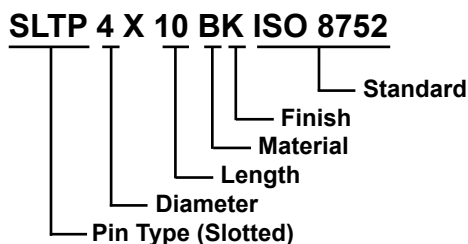

MATERIALS

Carbon steel: AISI 1070 - 1080
Equivalents: DIN 177222 WkNr 1.1248 CK75 & WkNr 1.1231 CK67 BS 1449 67CS & 70CS
Martensitic Stainless Steel: AISI 420
Equivalents: DIN 17441 WkNr 1.4021 BS 1449-2 420S45
Austenitic Stainless Steels: AISI 302/304
Equivalents: EN 10088 / DIN 17224 WkNr 1.4300 & WkNr 1.4301 BS 1449-2 304S31
Beryllium Copper: UNS C17200
Equivalents: DIN 17666 WkNr 2.1248 ISO CuBe2Pb

SPIROL® THE CHOICE – ASME OR ISO

SPIROL produces Slotted Pins to both the American National Standard, ASME B18.8.4M and the International Standard, ISO 8752 (EN 28752). It is our recommendation that you consider ASME pins for all new applications and for your current applications if you are experiencing insertion problems or performance failures. Our recommendation is based on these important advantages of ASME pins:

- ⊙ **LOWER INSERTION FORCE** as a result of the smaller free diameter of the pin in relation to the nominal hole. The pin is securely retained in the hole based on increased wall thickness, higher minimum hardness, and the minimal slot after insertion.
- ⊙ **NO INTERLOCKING** because the maximum gap in the free diameter state is always less than the wall thickness of the pin.
- ⊙ **HIGHER SHEAR STRENGTH** based on increased wall thickness, a higher minimum hardness, and narrower slots which close under load to ensure that the pins fail instantaneously rather than progressively in shear.

SHEAR STRENGTH COMPARISON

Nom. Dia.	ISO kN	ASME kN	Increase %
1.5	1.58	1.8	+11.4
2	2.82	3.5	+12.4
2.5	4.38	5.5	+12.6
3	6.32	7.8	+12.4
4	11.24	12.3	+9.4
5	17.54	19.6	+11.2
6	26.04	28.5	+9.4
8	42.76	48.8	+11.4
10	70.16	79.1	+12.6
12	104.1	111.6*	+7.2
14	144.7	170.0	+17.5
16	190.0	171.0	+11.1
18	250.0	222.5	+12.4
20	320.0	280.6	+11.4

* SPIROL standard.



COMPARISON OF RECOMMENDED HOLES

ASME recommends tolerance class H10 for holes up to 2.5 mm and H12 for diameters 3 mm and larger. ISO recommends H12 for all diameters.

Nom. Dia.	ISO	ASME
1.5	1.5 / 1.6	1.5 / 1.56
2	2 / 2.1	2 / 2.07
2.5	2.5 / 2.65	2.5 / 2.58
3 and up	No difference	No difference

ASME pins 3 mm and larger can be substituted for ISO pins without any review or change. 1.5 to 2.5 mm pins require a change in the maximum specified hole.

COMPARISON OF TECHNICAL SPECIFICATIONS

EXPANDED DIAMETER – ASME pins have a smaller expanded or free diameter relative to the nominal hole.

CHAMFER SPECIFICATION – ASME specifies a maximum chamfer diameter from 0.1 to 0.5 mm smaller than the nominal hole diameter whereas ISO only specifies a chamfer diameter less than the nominal hole diameter.

STRAIGHTNESS – ASME specifies a straightness requirement. ISO does not address it at all.

SHEAR STRENGTH – ASME specifies a minimum double shear strength for austenitic stainless steel. ISO does not.

MATERIAL – ASME includes Beryllium Copper. ISO does not.

LENGTH TOLERANCE – The differences are minimal:

Pin Length	ISO	ASME
4 - 10 mm	± 0.25 mm	± 0.40 mm
12 - 24 mm	± 0.50 mm	± 0.40 mm
26 - 50 mm	± 0.50 mm	± 0.50 mm
55 - 75 mm	± 0.75 mm	± 0.60 mm
80 - 100 mm	± 0.75 mm	± 0.75 mm

WALL THICKNESS – ASME pins have a wall thickness equal to or greater than ISO pins and a greater cross sectional area based on both thickness and strip width.

HARDNESS – The ASME specification for carbon steel is higher (HV 458-560 vs HV 420-520) to maximize the tensile strength and for chrome stainless it is slightly lower (HV 423-544 vs HV 440-560) to avoid the risk of brittleness.

ISO 8752 EN 28752

PIN MATERIALS AND HARDNESS

PIN FINISHES

B Carbon Steel	HV 420-520	K Plain*
C Martensitic Stainless Steel	HV 440-560	P Passivated
D Austenitic Stainless Steel	Work Hardened	T Zinc Plated

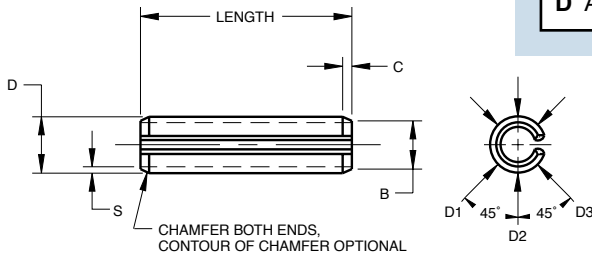

* Plain carbon steel pins have a protective oil finish.

B IS LESS THAN NOMINAL PIN DIAMETER

SPECIFICATIONS in mm

Nominal Pin Diameter	Pin Diameter D		Chamfer Length C	Wall Thickness S	Recommended Hole Size		Double Shear Strength Carbon & Martensitic S.S.
	Min. ¹	Max. ²	Nominal	Nominal	Min.	Max.	Minimum kN
1.5	1.7	1.8	0.25	0.3	1.5	1.60	1.58
2	2.3	2.4	0.35	0.4	2.0	2.10	2.82
2.5	2.8	2.9	0.40	0.5	2.5	2.60	4.38
3	3.3	3.5	0.50	0.6	3.0	3.10	6.32
3.5	3.8	4.0	0.60	0.75	3.5	3.62	9.09
4	4.4	4.6	0.65	0.8	4.0	4.12	11.24
4.5*	4.9	5.1	0.80	1.0	4.5	4.62	15.36
5	5.4	5.6	0.90	1.0	5.0	5.12	17.54
6	6.4	6.7	1.20	1.2	6.0	6.12	26.04
8	8.5	8.8	2.00	1.5	8.0	8.15	42.76
10	10.5	10.8	2.00	2.0	10.0	10.15	70.16
12	12.5	12.8	2.00	2.5	12.0	12.18	104.1
14*	14.5	14.8	2.00	3.0	14.0	14.18	144.7 ³
16	16.5	16.8	2.00	3.0	16.0	16.18	171.0 ³
18*	18.5	18.9	2.00	3.5	18.0	18.18	222.5 ³
20	20.5	20.9	3.00	4.0	20.0	20.21	280.6 ³

¹ Minimum diameter is the average of D1, D2, and D3. ² Maximum measured with go-ring gauge. ³ Carbon Steel only.

STANDARD LENGTHS AND WEIGHTS (Kg PER 1,000 PCS.)

Length	Diameter																	
	1.5	2	2.5	3	3.5	4	4.5*	5	6	8	10	12	14*	16	18*	20		
4	0.034	0.061																
5	0.043	0.077																
6	0.051	0.092	0.118	0.204														
8	0.068	0.122	0.142	0.272	0.394	0.478												
10	0.085	0.153	0.189	0.340	0.493	0.597	0.793	0.942										
12	0.103	0.184	0.236	0.407	0.591	0.716	0.952	1.13	1.66									
14	0.120	0.214	0.283	0.475	0.689	0.836	1.11	1.32	1.94									
16	0.137	0.244	0.330	0.543	0.788	0.955	1.27	1.51	2.21	3.58								
18	0.154	0.275	0.377	0.611	0.886	1.07	1.43	1.70	2.49	4.03								
20	0.171	0.305	0.424	0.679	0.985	1.19	1.59	1.88	2.77	4.48	7.38							
22	0.189	0.336	0.471	0.746	1.08	1.31	1.75	2.07	3.04	4.92	8.12							
24	0.206	0.367	0.519	0.814	1.18	1.43	1.90	2.26	3.32	5.37	8.86	13.3						
26	0.223	0.397	0.565	0.882	1.28	1.55	2.06	2.45	3.60	5.82	9.59	14.4						
28	0.240	0.427	0.613	0.950	1.38	1.67	2.22	2.64	3.87	6.26	10.3	15.6						
30		0.458	0.660	1.02	1.48	1.79	2.38	2.83	4.15	6.71	11.1	16.7	23.4					
32		0.489	0.707	1.09	1.58	1.91	2.54	3.02	4.43	7.16	11.8	17.8						
35		0.534	0.754	1.19	1.72	2.09	2.86	3.31	4.84	7.83	12.9	19.4	27.3	32.2				
40		0.610	0.825	1.36	1.97	2.39	3.17	3.77	5.54	8.95	14.8	22.2	31.2	36.7	49.0	61.2		
45			0.942	1.53	2.22	2.68	3.57	4.24	6.23	10.1	16.6	25.0	35.1	41.3	55.1	68.9		
50			1.06	1.70	2.46	2.98	3.96	4.71	6.92	11.2	18.4	27.8	39.0	45.9	61.3	76.5		
55							3.28	4.36	5.18	7.61	12.3	20.3	30.5	42.9	50.5	67.4	84.2	
60							3.58	4.76	5.65	8.30	13.4	22.1	33.3	46.8	55.1	73.5	91.8	
65										8.99	14.5	24.0	36.1	50.1	59.7	79.6	99.5	
70										9.69	15.7	25.8	38.9	54.6	64.3	85.8	107.1	
75										10.4	16.8	27.7	41.7	58.5	68.9	91.9	114.8	
80											18.0	29.5	44.4	62.4	73.5	98.0	122.4	
85												19.0	31.4	47.2	66.3	78.1	104.1	130.1
90												20.1	33.2	50.0	70.2	82.7	110.3	137.7
95												21.3	35.0	52.8	74.1	87.3	116.4	145.4
100												22.4	36.9	55.5	77.9	91.9	122.5	153.0

* Not generally a stocked diameter.

ASME B18.8.4M TYPE B

PIN MATERIALS AND HARDNESS

PIN FINISHES

B Carbon Steel	HV 458-560	K Plain*
C Martensitic Stainless Steel	HV 423-544	P Passivated
D Austenitic Stainless Steel	Work Hardened	T Zinc Plated
I Beryllium Copper	HV 354-412	R Phosphated, Oiled

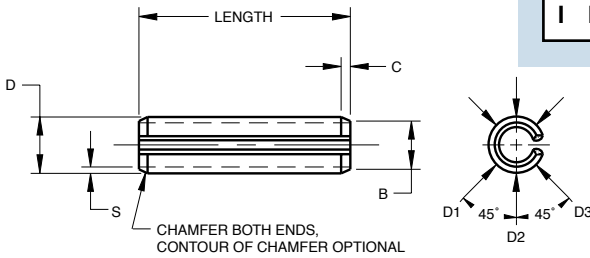

* Plain carbon steel pins have a protective oil finish.

SPECIFICATIONS in mm

Nominal Pin Diameter	Pin Diameter D		Chamfer Diameter B	Chamfer Length C		Wall Thickness S	Recommended Hole Size		Double Shear Strength		
	Min. ¹	Max. ²		Min.	Max.		Min.	Max.	Carbon & Martensitic S.S.	Austenitic S.S.	Beryllium Copper
	Minimum kN										
1.5	1.58	1.66	1.4	0.15	0.7	0.35	1.5	1.56	1.8	1.0	1.1
2	2.10	2.19	1.9	0.2	0.8	0.45	2.0	2.07	3.5	2.0	2.2
2.5	2.62	2.72	2.4	0.2	0.9	0.55	2.5	2.58	5.5	3.2	3.5
3	3.14	3.25	2.9	0.2	1.0	0.65	3.0	3.10	7.8	4.5	4.9
4	4.16	4.30	3.9	0.3	1.2	0.8	4.0	4.12	12.3	7.2	7.7
5	5.17	5.33	4.8	0.3	1.4	1.0	5.0	5.12	19.6	11.4	12.3
6	6.18	6.36	5.8	0.4	1.6	1.2	6.0	6.12	28.5	16.6	17.8
8	8.22	8.45	7.8	0.4	2.0	1.6	8.0	8.15	48.8	28.4	30.5
10	10.25	10.51	9.7	0.5	2.4	2.0	10.0	10.15	79.1	46.1	49.4
12	12.28	12.55	11.7	0.6	2.8	2.5	12.0	12.18	111.6 ³	60.7	65.0
14†*	14.30	14.60	13.7	0.8	2.8	3.0	14.0	14.18	170.0 ⁴	—	—
16†	16.32	16.65	15.6	1.0	3.0	3.0	16.0	16.18	190.0 ⁴	—	—
18†*	18.35	18.71	17.6	1.2	3.2	3.5	18.0	18.18	250.0 ⁴	—	—
20†	20.40	20.80	19.5	1.4	3.4	4.0	20.0	20.21	320.0 ⁴	—	—

¹ Minimum diameter is the average of D1, D2, and D3. ² Maximum measured with go-ring gauge. ³ SPIROL standard. ⁴ Carbon Steel only.

STANDARD METRIC SIZES AND WEIGHTS (Kg PER 1,000 PCS.)

Length	Diameter													
	1.5	2	2.5	3	4	5	6	8	10	12	14†*	16†	18†*	20†
4	0.042	0.071												
5	0.052	0.089	0.136											
6	0.062	0.107	0.163	0.231										
8	0.083	0.143	0.218	0.308	0.512									
10	0.104	0.179	0.272	0.386	0.640	1.002								
12	0.125	0.214	0.327	0.463	0.768	1.203	1.723							
14	0.145	0.250	0.381	0.540	0.896	1.403	2.011							
16	0.166	0.286	0.436	0.617	1.024	1.604	2.298	3.947						
18	0.187	0.321	0.490	0.694	1.152	1.804	2.585	4.441						
20	0.208	0.357	0.545	0.771	1.280	2.005	2.872	4.934	7.640					
22	0.228	0.393	0.599	0.848	1.408	2.205	3.159	5.427	8.404	12.603				
24	0.249	0.429	0.653	0.925	1.536	2.406	3.447	5.921	9.168	13.749				
26	0.270	0.464	0.708	1.003	1.664	2.606	3.734	6.414	9.932	14.895				
28	0.291	0.500	0.762	1.080	1.792	2.807	4.021	6.907	10.696	16.041				
30		0.536	0.817	1.157	1.920	3.007	4.308	7.401	11.460	17.186	23.497			
32		0.571	0.871	1.234	2.048	3.208	4.596	7.894	12.224	18.332	25.064			
35		0.625	0.953	1.350	2.240	3.508	5.026	8.634	13.370	20.051	27.413			
40		0.714	1.089	1.542	2.560	4.010	5.744	9.868	15.280	22.915	31.330	37.729	48.872	61.319
45				1.735	2.880	4.511	6.463	11.101	17.190	25.780	35.246	42.445	54.980	68.984
50					3.200	5.012	7.181	12.335	19.100	28.644	39.162	47.162	61.089	76.649
55					3.519	5.513	7.899	13.568	21.009	31.508	43.078	51.878	67.198	84.314
60							8.617	14.802	22.919	34.373	46.994	56.594	73.307	91.979
65							9.335	16.035	24.829	37.237	50.911	61.310	79.416	99.643
70							10.053	17.269	26.739	40.102	54.827	66.026	85.525	107.308
75							10.771	18.502	28.649	42.966	58.743	70.742	91.634	114.973
80								19.736	30.559	45.830	62.659	75.458	97.743	122.638
85								20.969	32.469	48.695	66.575	80.175	103.852	130.303
90								22.203	34.379	51.559	70.492	84.891	109.961	137.968
95								23.436	36.289	54.423	74.708	89.607	116.070	145.633
100								24.670	38.199	57.288	78.324	94.323	122.179	153.298

† In conformance with but not part of ASME 18.18.4M.

* Not generally a stocked diameter.

ASME B18.8.2

PIN MATERIALS AND HARDNESS

PIN FINISHES

B Carbon Steel	HV 458-560	K Plain*
C Martensitic Stainless Steel	HV 423-544	P Passivated
D Austenitic Stainless Steel	Work Hardened	T Zinc Plated
I Beryllium Copper	HV 354-412	R Phosphated, Oiled

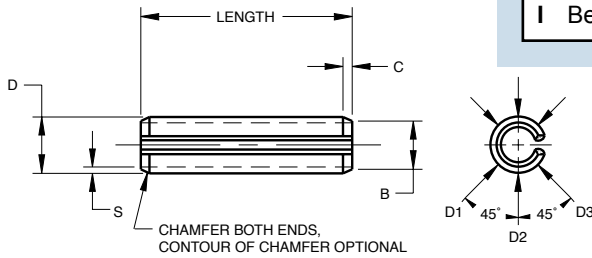

* Plain carbon steel pins have a protective oil finish.

SPECIFICATIONS in inches

Nominal Pin Diameter	Pin Diameter D		Chamfer Diameter B	Chamfer Length C		Wall Thickness S	Recommended Hole Size		Double Shear Strength							
	Min. ¹	Max. ²	Max.	Min.	Max.	Nom.	Min.	Max.	Carbon & Martensitic S.S.			Austenitic S.S.			Beryllium Copper	
	Minimum Lbs. and kN															
1/16	.062	.066	.069	.059	.007	.028	.012	.062	.065	430	2.00	250	1.10	270	1.20	
5/64	.078	.083	.086	.075	.008	.032	.018	.078	.081	800	3.56	460	2.05	500	2.22	
3/32	.094	.099	.103	.091	.008	.038	.022	.094	.097	1150	5.12	670	2.98	710	3.16	
1/8	.125	.131	.135	.122	.008	.044	.028	.125	.129	1875	8.34	1090	4.85	1170	5.20	
5/32	.156	.162	.167	.151	.010	.048	.032	.156	.160	2750	12.23	1600	7.12	1725	7.67	
3/16	.187	.194	.199	.182	.011	.055	.040	.187	.192	4150	18.46	2425	10.79	2600	11.57	
7/32	.219	.226	.232	.214	.011	.065	.048	.219	.224	5850	26.02	3400	15.12	3650	16.24	
1/4	.250	.258	.264	.245	.012	.065	.048	.250	.256	7050	31.36	4100	18.24	4400	19.57	
5/16	.312	.321	.330	.306	.014	.080	.062	.312	.318	10800	48.04	6300	28.02	6750	30.03	
3/8	.375	.385	.395	.368	.016	.095	.077	.375	.382	16300	72.50	9500	42.25	10200	45.37	
7/16	.437	.448	.459	.430	.017	.095	.077	.437	.445	19800	88.08	11500	51.16	12300	54.72	
1/2	.500	.513	.524	.485	.025	.110	.094	.500	.510	27100	120.55	15800	70.28	17000	75.62	
5/8 ³	.625	.640	.653	.608	.030	.125	.118	.625	.637	42500	189.06	—	—	—	—	
3/4 ³	.750	.768	.784	.730	.045	.150	.145	.750	.764	62500	278.02	—	—	—	—	

¹ Minimum diameter is average of D1, D2 and D3. ² Maximum diameter measured with go-ring gauge. ³ SPIROL standard, Carbon Steel only.

STANDARD SIZES AND WEIGHTS (Lbs. PER 1,000 PCS.)

Length	Nominal Diameter														
	1/16	5/64	3/32	1/8	5/32	3/16	7/32	1/4	5/16	3/8	7/16	1/2	5/8*	3/4*	
3/16	.09	.19	.26												
1/4	.12	.25	.34												
5/16	.15	.32	.42	.68											
3/8	.18	.38	.50	.82											
7/16	.21	.44	.58	.96	1.46										
1/2	.24	.50	.66	1.11	1.68	2.35	3.25	4.10							
9/16	.27	.56	.74	1.25	1.90	2.66	3.69	4.35							
5/8	.30	.62	.82	1.39	2.12	2.98	4.13	4.60							
11/16	.33	.68	.90	1.54	2.34	3.29	4.57	5.15							
3/4	.36	.74	.98	1.68	2.56	3.60	5.00	5.80	9.23	13.5					
13/16	.39	.80	1.06	1.83	2.78	3.91	5.44	6.35	10.05						
7/8	.42	.86	1.14	1.98	3.00	4.23	5.88	6.90	10.87	16.0					
15/16	.45	.92	1.22	2.12	3.22	4.54	6.31	7.45	11.69						
1	.48	.98	1.30	2.26	3.44	4.85	6.75	8.00	12.51	18.5	23.4				
1-1/8		1.09	1.48	2.56	3.85	5.48	7.63	9.10	14.15						
1-1/4		1.20	1.64	2.86	4.27	6.10	8.51	10.20	15.79	23.5	29.4	36.5			
1-3/8		1.31	1.80	3.16	4.69	6.73	9.39	11.30	17.43						
1-1/2		1.42	1.96	3.46	5.11	7.35	10.27	12.40	19.07	28.5	35.4	45.0			
1-5/8				3.77	5.53	7.98	11.15	13.50	20.71						
1-3/4				4.07	5.95	8.60	12.03	14.60	22.45	33.5	41.4	53.5			
1-7/8				4.47	6.37	9.23	12.91	15.70	24.09						
2				4.68	6.79	9.85	13.79	16.80	25.73	38.5	47.4	62.0	115.5	154.2	
2-1/4					7.63	11.10	15.55	19.00	29.01	43.5	53.4	70.5	129.9	173.5	
2-1/2					8.47	12.35	16.31	21.20	32.29	48.5	59.4	79.0	144.4	192.8	
2-3/4								1807	23.40	35.57	53.5	65.4	87.5	158.8	212.0
3								19.83	25.60	38.85	58.5	71.4	96.0	173.3	231.3
3-1/4									27.80	42.13	63.5	77.4	104.5	187.7	250.6
3-1/2									30.00	45.41	68.5	83.4	113.0	202.1	269.9
3-3/4										48.69	73.5	89.4	121.5	216.6	289.1
4										51.97	78.5	95.4	130.0	231.0	308.4

* SPIROL standards.

SPIROL[®] TECHNICAL INFORMATION

SHEAR STRENGTH

The shear test procedure is set forth in B18.8.2-2000, ISO 8752, SAE J496, and NASM 10971, which are identical in substance.

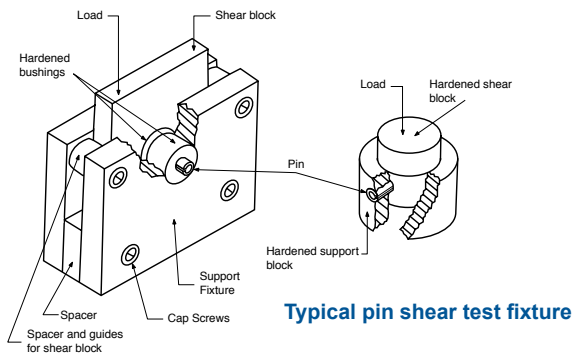

Typical pin shear test fixture

Shear values specified will only be obtained under the conditions noted in the referenced standards. Of special note:

- ⊙ The clearance at the shear plane cannot exceed 0.15 mm or .005".
- ⊙ The hole has to be the nominal pin diameter (tolerance H6) with a hardness of not less than HV 700.
- ⊙ The shear planes have to be at least one pin diameter from each end, and at least two diameters apart.

STRAIGHTNESS SPECIFICATION (ASME PINS ONLY)

The straightness over the length of the pins shall be such that the pins will pass freely through a ring gauge of the length and diameter as specified below.

STRAIGHTNESS GAUGE SPECIFICATIONS

Pin Length	Gauge Length		Maximum Pin Diameter Plus	
	Min.	Max.	Min.	Max.
Up to 24 mm	25 ± 0.15		0.20 – 0.22	
Up to 1"	1" ± .005"		.007"	
24 mm – 50 mm	50 ± 0.15		0.40 – 0.43	
1" – 2"	2" ± .005"		.010"	
Over 50 mm	75 ± 0.15		0.60 – 0.64	
Over 2"	3" ± .005"		.013"	

RECOMMENDED PIN/SHAFT RATIO

The recommended maximum ratio is 1 to 3; that is the pin diameter should never exceed 33.3% of the shaft diameter. If this limit is exceeded, the remaining material in the shaft is inadequate and the shaft will fail before the pin.

DOUBLE PINNING

In situations requiring exceptionally high shear strength, it is possible to use pins in combination by driving an inner pin into an already inserted outer pin. The gaps should be 180° opposed. The recommended hole needs to be increased. It is suggested you consult Spirol Application Specialists in these situations.

WHICH STAINLESS?

Martensitic chrome stainless is hardened and has strength comparable to carbon steel and satisfactory corrosion resistance in most cases. Austenitic nickel stainless steel has better corrosion resistance in some environments but since it is not hardened, it has lower strength and requires more care in the insertion process.

HOLE PREPARATION

Holes can be drilled, punched or cast with no need for additional reaming or sizing. Care should be taken to avoid undersize holes to eliminate potential pin damage during insertion. The following points are suggested for your consideration:

- ⊙ Break or debur the edges, particularly in case of hardened holes.
- ⊙ Countersinking is not recommended if it increases the clearance at the shear plane.
- ⊙ In case of cast or sintered metal holes, provide a lead-in radius.
- ⊙ Whenever possible, punched holes should be punched in the same direction as the direction of pin insertion.
- ⊙ Eliminate hole misalignment problems by drilling holes together.
- ⊙ In case of hardened collars or similar components, flatten the component at the entry of the hole to avoid two-point contact as the pin starts into the hole.

SPECIALS

ISO 13337 (DIN 7346) SPECIFICATIONS

Nom. Pin Diameter	Expanded Diameter		Chamfer Length		Wall Thickness	Double Shear Strength Carbon & Martensitic S.S. Min. kM
	Min.	Max.	Min.	Max.	Nominal	
2	2.3	2.4	0.20	0.40	0.20	1.50
2.5	2.8	2.9	0.25	0.45	0.25	2.40
3	3.3	3.5	0.25	0.45	0.30	3.50
4	4.4	4.6	0.50	0.70	0.50	8.00
5	5.4	5.6	0.50	0.70	0.50	10.40
6	6.4	6.7	0.70	0.90	0.75	18.00
8	8.5	8.8	0.70	0.90	0.75	24.00
10	10.5	10.8	0.90	1.10	1.00	40.00

OTHER COMMON SPECIALS:

- ⊙ Special Lengths
- ⊙ Special Materials
- ⊙ Special Tolerances
- ⊙ Special Finishes
- ⊙ Special Packaging

SPIROL®

INTERNATIONAL

Applications

SPIROL® slotted spring pins are used in many industries.

- Agriculture
- Automotive
- Construction
- Appliances
- Electronics
- Furniture
- Mining
- Plastics
- Railways
- Aerospace

Typical applications use spring pins as...

- Fasteners to secure handles and gears to shafts
- Retaining pins
- Axle shafts
- Stop pins
- Hinge and pivot applications
- Cross bars
- Tube reinforcing pins
- Locator pins



**FREE APPLICATION AND
INSERTION CONSULTATION**

ISO/TS 16949:2002 Certified

Challenge Us!

© 2010 Spirol International Corporation 02/10

U.S.A. Spirol International Corporation
30 Rock Avenue
Danielson, Connecticut 06239
Tel. +1 (1) 860.774.8571
Fax. +1 (1) 860.774.2048

Spirol West Inc.
1950 Compton Avenue, Unit 111
Corona, California 92881-6471
Tel. +1 (1) 951.273.5900
Fax. +1 (1) 951.273.5907

**Spirol International Corporation
Shim Division**
321 Remington Road
Stow, Ohio 44224
Tel. +1 (1) 330.920.3655
Fax. +1 (1) 330.920.3659

Spirol Distribution
(For Distributor Customers)
30 Rock Avenue
Danielson, Connecticut 06239
Tel. +1 (1) 860.774.8571
Fax. +1 (1) 860.774.0487

Canada Spirol Industries, Ltd.
3103 St. Etienne Boulevard
Windsor, Ontario
Canada N8W 5B1
Tel. +1 (1) 519.974.3334
Fax. +1 (1) 519.974.6550

Mexico Spirol México, S.A. de C.V.
Carretera a Laredo KM 16.5 Interior E
Col. Moisés Saenz
Apodaca, N.L. 66613 México
ó Apdo. Postal 151 de Apodaca, N.L.
Tel. +52 (01) 81 8385 4390
Fax. +52 (01) 81 8385 4391

Europe Spirol Industries, Ltd.
Princeton Road
Corby, Northants
England NN17 4ET
Tel. +44 (0) 1536 444800
Fax. +44 (0) 1536 203415
(UK Distributors: Tel. 0800 3890034)

Spirol SAS
Rue Henri Rol Tanguy
Z.A. Les Naux
51450 Bétheny - Reims
France
Tel. +33 (0) 3 26 36 31 42
Fax. +33 (0) 3 26 09 19 76

Spirol GmbH
Brienner Strasse 9
80333 Munich
Germany
Tel. +49 (0) 931 454 670 74
Fax. +49 (0) 931 454 670 75

**Asia Pacific Spirol International Engineered
Fastener Trading Co. Ltd.**
No. 11 Xi Ya Rd. North
Section A, 1F, Building 14
Wai Gao Qiao Free Trade Zone
Shanghai, China 200131
Tel. +86 (0) 21 5046-1451/1452
Fax. +86 (0) 21 5046-1540

e-mail: info@spirol.com

SPIROL.com