

# SPIROL®

## PRESS-N-LOK™ PINS FOR PLASTICS

### SPIROL® Series BP100 Press-N-Lok™ Pins

**Press-N-Lok™ Pins** were designed to permanently retain two plastic components to each other. The raised barbs are angled backwards on the pin, opposite the direction of insertion. Press-N-Lok™ Pins are installed in two stages: First, press the pins into one half of the plastic housing. Next, align the other half of the housing with the exposed pins and press into place. During installation, the plastic will backfill into the area around the barbs resulting in maximum resistance to axial force. Make assembly simple and quick; just Press-N-Lok™!

#### Advantages

- Permanent / tamper resistant
- Simple & clean installation
- Lightweight & **lead free**
- Corrosion resistant
- Quicker assembly time and lower assembly equipment costs compared to screws and adhesives
- Hidden within the final assembly

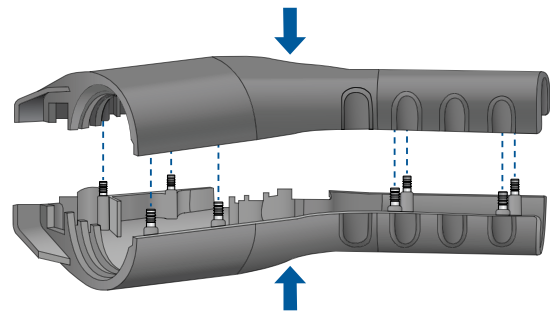

**Application Example:**  
Press-N-Lok™ Pins in an Electric Vehicle Charging Handle

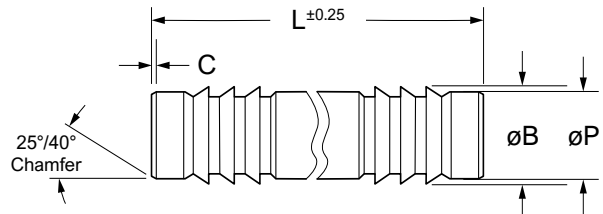

#### DIMENSIONAL DATA — METRIC

Nominal Diameter	Pilot Diameter "P"		Barb Diameter "B"		Barb Count (per side) #	Chamfer Length "C" Min.	Pin Length "L"	Recommended Hole Size	
	Min.	Max.	Min.	Max.				Min.	Max.
2	1.90	2.00	2.25	2.40	2	0.15	8	2.00	2.10
							12		
							16		
3	2.90	3.00	3.25	3.40	3	0.20	12	3.00	3.10
							18		
							24		
4	3.90	4.00	4.25	4.40	4	0.30	16	4.00	4.10
							24		
							32		

**STANDARD MATERIAL** A Aluminum      **STANDARD FINISH** K Plain

- Other lengths available upon request
- Available to order in nickel stainless steel

**To Order:** SLDP (Pin Size)x(Length)(Material)(Finish)(Series)  
**Example:** SLDP 3 x 12 AK BP100

**Contact SPIROL for Design Assistance!**  
[www.SPIROL.com/technical-support](http://www.SPIROL.com/technical-support)





**Innovative fastening solutions.  
Lower assembly costs.**

## Technical Centers

**Americas** **SPIROL International Corporation**  
30 Rock Avenue  
Danielson, Connecticut 06239 U.S.A.  
Tel. +1 860 774 8571  
Fax. +1 860 774 2048

**SPIROL Shim Division**  
321 Remington Road  
Stow, Ohio 44224 U.S.A.  
Tel. +1 330 920 3655  
Fax. +1 330 920 3659

**SPIROL Canada**  
3103 St. Etienne Boulevard  
Windsor, Ontario N8W 5B1 Canada  
Tel. +1 519 974 3334  
Fax. +1 519 974 6550

**SPIROL Mexico**  
Avenida Avante #250  
Parque Industrial Avante Apodaca  
Apodaca, N.L. 66607 Mexico  
Tel. +52 81 8385 4390  
Fax. +52 81 8385 4391

**SPIROL Brazil**  
Rua Mafalda Barnabé Soliane, 134  
Comercial Vitória Martini, Distrito Industrial  
CEP 13347-610, Indaiatuba, SP, Brazil  
Tel. +55 19 3936 2701  
Fax. +55 19 3936 7121

**Europe** **SPIROL United Kingdom**  
17 Princewood Road  
Corby, Northants  
NN17 4ET United Kingdom  
Tel: +44 (0) 1536 444800  
Fax: +44 (0) 1536 203415

**SPIROL France**  
Cit  de l'Automobile ZAC Croix Blandin  
18 Rue L na Bernstein  
51100 Reims, France  
Tel: +33 (0) 3 26 36 31 42  
Fax: +33 (0) 3 26 09 19 76

**SPIROL Germany**  
Ottostr. 4  
80333 Munich, Germany  
Tel: +49 (0) 89 4 111 905 71  
Fax: +49 (0) 89 4 111 905 72

**SPIROL Spain**  
Plantes 3 i 4  
Gran Via de Carles III, 84  
08028, Barcelona, Spain  
Tel/Fax: +34 932 71 64 28

**SPIROL Czech Republic**  
Evropsk 2588 / 33a  
160 00 Prague 6-Dejvice  
Czech Republic  
Tel: +420 226 218 935

**SPIROL Poland**  
ul. Solec 38 lok. 10  
00-394, Warsaw, Poland  
Tel. +48 510 039 345

**Asia Pacific** **SPIROL Asia Headquarters**  
1st Floor, Building 22, Plot D9, District D  
No. 122 HeDan Road  
Wai Gao Qiao Free Trade Zone  
Shanghai, China 200131  
Tel: +86 (0) 21 5046-1451  
Fax: +86 (0) 21 5046-1540

**SPIROL Korea**  
16th Floor, 396 Seocho-daero,  
Seocho-gu, Seoul, 06619, South Korea  
Tel: +82 (0) 10 9429 1451

e-mail: [info@spirol.com](mailto:info@spirol.com)

**SPIROL.com**



**Coiled Spring Pins**



**Slotted Spring Pins**



**Solid Pins**



**Alignment Dowels /  
Bushings**

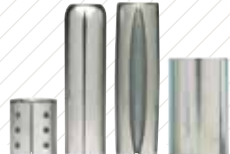

**Spacers & Rolled  
Tubular Components**

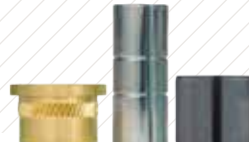

**Compression  
Limiters**



**Threaded Inserts  
for Plastics**



**Railroad Nuts**



**Disc Springs**



**Precision Shims &  
Thin Metal Stampings**

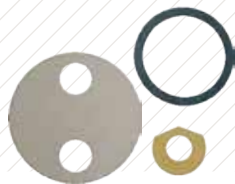

**Precision Washers**



**Parts Feeding  
Technology**



**Pin Installation  
Technology**



**Insert Installation  
Technology**



**Compression Limiter  
Installation Technology**

Please refer to [www.SPIROL.com](http://www.SPIROL.com) for current specifications and standard product offerings.

SPIROL offers complimentary Application Engineering support! We will assist on new designs as well as help resolve issues, and recommend cost savings on existing designs. Let us help by visiting **Application Engineering Services** on **SPIROL.com**.