

SPIROL[®]

INSERT INSTALLATION TECHNOLOGY

Model HM

Manual Heat Insert Driver

As much as 75% of an Insert's performance is the direct result of how well it was installed. Therefore, in order to maximize performance, all of the factors that impact installation must be carefully controlled. **SPIROL's Model HM Manual Insert Driver** has been designed to eliminate the dependency on the operator to control these factors. The result is nearly perfect flow of the plastic for optimal retention and performance.

Designed to install virtually any type of Heat/Ultrasonic Style Insert

Standard Features:

- Internal air-spring installation system for infinitely adjustable and consistent force
- Easily adjustable, digital temperature controller
- Easily interchangeable heat tips to accommodate various Insert sizes and applications

The Model HM is:

- Easy:** - Simple to operate and easily adjustable
- Accurate:** - Base plate is pre-drilled for simple and precise fixture location
- Reliable:** - Post mount style frame is sturdy, lightweight, and portable
- Precise:** - Micrometer style insertion depth stop for accurate, consistent installations
- Versatile:** - Installs Inserts ranging in sizes from M2 to M6 metric threads and No. 2 to 1/4" unified threads, and the simple up-down adjustment of the machine makes it easy to accommodate various sized components

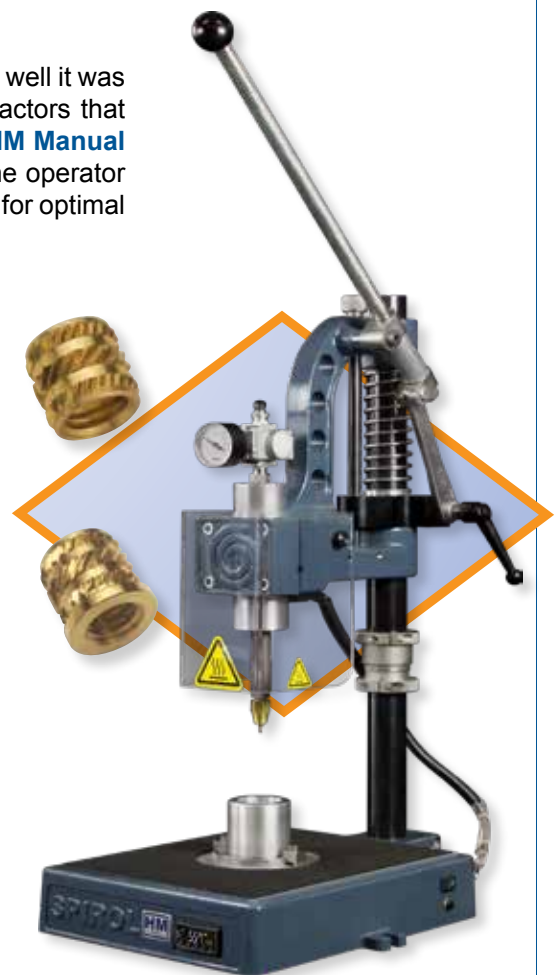

*Model HM
—
Shown with
optional fixture*

Optional alignment fixtures available.

**Automated installation machines
are also available from SPIROL.**



Application:

A molder of plastic yo-yos wanted to introduce a higher quality product to the market. By incorporating threaded Brass Inserts into each half of the yo-yo, a higher quality joint would be created resulting in a truer rotational axis. Inserts also provide reusable threads which would enable unlimited assembly and disassembly without damage to the plastic. The molder wanted to utilize existing molds, as well as minimize the investment required to install the Inserts. The high heat and limited space made manual loading of the Insert into the mold undesirable. There was also the potential for a mis-loaded Insert to cause costly damage to the mold.

Solution:

SPIROL's Engineers reviewed the application, and recommended that a symmetrical brass Insert be used in conjunction with several economical **SPIROL Model HM Manual Heat Inserters**. The HM heat machines were lined up in a portable production work cell. The symmetrical design made placement of the Insert in the yo-yo's hole quick and easy. The HM machine has only two settings, temperature and air pressure, making it extremely easy to use. The operator places the Insert in the hole, pulls the handle on the press until it reaches a positive stop, and holds. The heated tip engages the Insert and transfers heat until the Insert reaches the correct melt temperature of the plastic. The compressed air, created by pulling the handle, then smoothly and consistently pushes the Insert into position. This system delivers exceptionally repeatable, quality installations that result in consistent Insert performance. The HM also provides versatility for future designs as it can easily be converted to install almost any size and style heat Insert.

SPIROL Application Engineers will review your application needs and work with your design team to recommend the best solution. One way to start the process is to select **Installation Systems** in our **Optimal Application Engineering** portal at www.SPIROL.com.

Technical Centers

Americas

SPIROL International Corporation
30 Rock Avenue
Danielson, Connecticut 06239 U.S.A.
Tel. +1 860 774 8571
Fax. +1 860 774 2048

SPIROL Shim Division
321 Remington Road
Stow, Ohio 44224 U.S.A.
Tel. +1 330 920 3655
Fax. +1 330 920 3659

SPIROL Canada
3103 St. Etienne Boulevard
Windsor, Ontario N8W 5B1 Canada
Tel. +1 519 974 3334
Fax. +1 519 974 6550

SPIROL Mexico
Avenida Avante #250
Parque Industrial Avante Apodaca
Apodaca, N.L. 66607 Mexico
Tel: +52 (01) 81 8385 4390
Fax: +52 (01) 81 8385 4391

SPIROL Brazil
Rua Mafalda Barnabé Soliane, 134
Comercial Vitória Martini, Distrito Industrial
CEP 13347-610, Indaiatuba, SP, Brazil
Tel. +55 19 3936 2701
Fax. +55 19 3936 7121

Europe

SPIROL France
Cit  de l'Automobile ZAC Croix Blandin
18 Rue L na Bernstein
51100 Reims, France
Tel. +33 3 26 36 31 42
Fax. +33 3 26 09 19 76

SPIROL United Kingdom
17 Princewood Road
Corby, Northants
NN17 4ET United Kingdom
Tel. +44 1536 444800
Fax. +44 1536 203415

SPIROL Germany
Ottostr. 4
80333 Munich, Germany
Tel. +49 89 4 111 905 71
Fax. +49 89 4 111 905 72

SPIROL Spain
08940 Cornell  de Llobregat
Barcelona, Spain
Tel. +34 93 669 31 78
Fax. +34 93 193 25 43

SPIROL Czech Republic
Sokola T my 743/16
Ostrava-Mari nsk  Hory 70900
Czech Republic
Tel/Fax. +420 417 537 979

SPIROL Poland
ul. Solec 38 lok. 10
00-394, Warszawa, Poland
Tel. +48 510 039 345

Asia Pacific

SPIROL Asia Headquarters
1st Floor, Building 22, Plot D9, District D
No. 122 HeDan Road
Wai Gao Qiao Free Trade Zone
Shanghai, China 200131
Tel. +86 21 5046 1451
Fax. +86 21 5046 1540

SPIROL Korea
160-5 Seokchon-Dong
Songpa-gu, Seoul, 138-844, Korea
Tel. +86 (0) 21 5046-1451
Fax. +86 (0) 21 5046-1540