

SPIROL®

Standard Lift and Roll Machine Base

SPIROL lift and roll machine bases are designed for large feeding systems and auxiliary assembly modules or machines that need to be moved into position quickly and easily. Lift the base using the hydraulic jack, roll it into position, lower it and level the base plate with the leveling pads.

The tables are also ideal bases for **SPIROL® Pin Inserters**, **Insert Drivers** and other assembly modules.

FEATURES

- ⊙ M.I.G. welded frames of 2-1/2" square 1/4" gauge structural tubing
- ⊙ Precision ground top plates welded to frames
- ⊙ 4" steel casters, two fixed and two swivel
- ⊙ 2-ton hydraulic jack
- ⊙ 3-7/8" leveling pads with 3/4" screws and jam nuts
- ⊙ 2" height adjustment using leveling pads

The bases are available in standard sizes for quick delivery.

Special sizes to meet specific needs are also readily available.

SPECIFICATIONS

A	B	C	D	ITEM NUMBER	DRAWING NUMBER	WEIGHT (LBS.)
30"	36"	1"	32"	177440-000	DP-59116	600
30"	48"			177447-000	DP-59117	750
36"	48"			177449-000	DP-59118	900
48"	60"			177450-000	DP-59119	1800

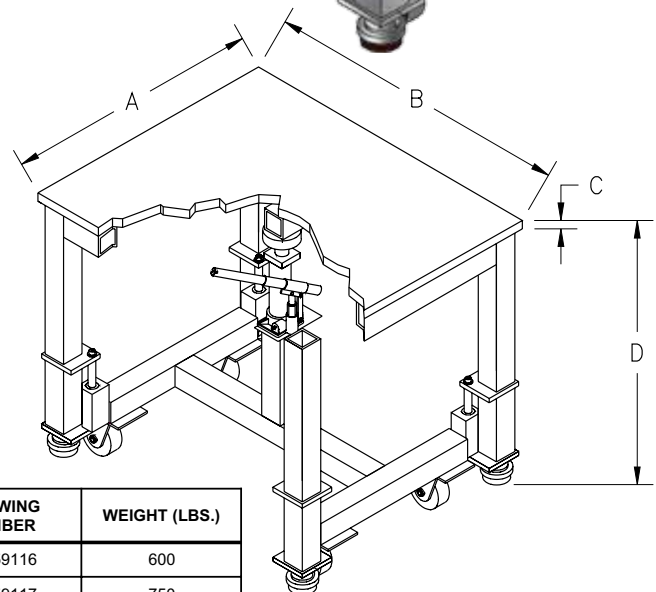

SPIROL®

Innovative fastening solutions.
Lower assembly costs.



Please refer to www.SPIROL.com for current specifications and standard product offerings.

SPIROL Application Engineers will review your application needs and work with you to recommend the optimum solution. One way to start the process is to visit our **Optimal Application Engineering** portal at **SPIROL.com**.

Technical Centers

Americas

SPIROL International Corporation
30 Rock Avenue
Danielson, Connecticut 06239 U.S.A.
Tel. +1 860 774 8571
Fax. +1 860 774 2048

SPIROL Shim Division
321 Remington Road
Stow, Ohio 44224 U.S.A.
Tel. +1 330 920 3655
Fax. +1 330 920 3659

SPIROL West
1950 Compton Avenue, Suite 112
Corona, California 92881 U.S.A.
Tel. +1 951 273 5900
Fax. +1 951 273 5907

SPIROL Canada
3103 St. Etienne Boulevard
Windsor, Ontario N8W 5B1 Canada
Tel. +1 519 974 3334
Fax. +1 519 974 6550

SPIROL Mexico
Carretera a Laredo KM 16.5 Interior E
Col. Moisés Saenz
Apodaca, N.L. 66613 Mexico
Tel. +52 81 8385 4390
Fax. +52 81 8385 4391

SPIROL Brazil
Rua Mafalda Barnabé Soliane, 134
Comercial Vitória Martini, Distrito Industrial
CEP 13347-610, Indaiatuba, SP, Brazil
Tel. +55 19 3936 2701
Fax. +55 19 3936 7121

Europe

SPIROL France
Cité de l'Automobile ZAC Croix Blandin
18 Rue Léna Bernstein
51100 Reims, France
Tel. +33 3 26 36 31 42
Fax. +33 3 26 09 19 76

SPIROL United Kingdom
17 Princewood Road
Corby, Northants
NN17 4ET United Kingdom
Tel. +44 1536 444800
Fax. +44 1536 203415

SPIROL Germany
Ottostr. 4
80333 Munich, Germany
Tel. +49 89 4 111 905 71
Fax. +49 89 4 111 905 72

SPIROL Spain
08940 Cornellà de Llobregat
Barcelona, Spain
Tel. +34 93 193 05 32
Fax. +34 93 193 25 43

SPIROL Czech Republic
Sokola Tůmy 743/16
Ostrava-Mariánské Hory 70900
Czech Republic
Tel/Fax. +420 417 537 979

SPIROL Poland
ul. M. Skłodowskiej-Curie 7E / 2
56-400, Oleśnica, Poland
Tel. +48 71 399 44 55

Asia Pacific

SPIROL Asia Headquarters
1st Floor, Building 22, Plot D9, District D
No. 122 HeDan Road
Wai Gao Qiao Free Trade Zone
Shanghai, China 200131
Tel. +86 21 5046 1451
Fax. +86 21 5046 1540

SPIROL Korea
160-5 Seokchon-Dong
Songpa-gu, Seoul, 138-844, Korea
Tel. +86 (0) 21 5046-1451
Fax. +86 (0) 21 5046-1540

e-mail: info@spirol.com