

SPIROL[®] HEADED PINS

Headed Pin Series FH100

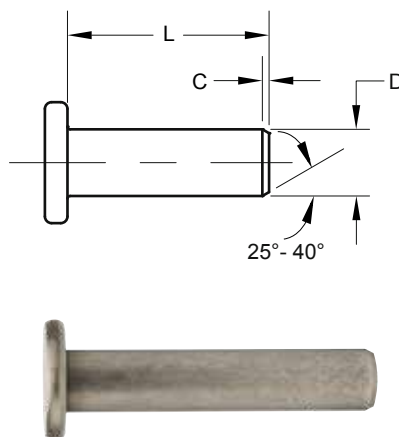

DIMENSIONAL DATA

Nominal Diameter ▶	INCH SPECIFICATIONS							METRIC SPECIFICATIONS						
		5/64 .078	3/32 .094	1/8 .125	5/32 .156	3/16 .187	1/4 .250		2	2.5	3	4	5	6
Diameter "D"	Min.	.0761	.0917	.1230	.1542	.1855	.2480	Min.	1.95	2.45	2.95	3.95	4.95	5.95
	Max.	.0781	.0937	.1250	.1562	.1875	.2500	Max.	2.00	2.50	3.00	4.00	5.00	6.00
Head Diameter	Min.	.132	.156	.209	.263	.312	.425	Min.	3.30	4.20	4.95	6.75	8.50	10.20
	Max.	.142	.172	.229	.283	.338	.451	Max.	3.70	4.60	5.45	7.25	9.10	10.80
Head Thickness	Min.	.022	.028	.036	.048	.060	.077	Min.	0.55	0.70	0.90	1.20	1.50	1.90
	Max.	.030	.036	.048	.060	.073	.090	Max.	0.75	0.90	1.20	1.50	1.80	2.20
Chamfer "C"	Min.	.005	.008	.008	.010	.015	.015	Min.	0.15	0.2	0.2	0.3	0.4	0.4
Length "L"	.250							6						
	.312							8						
	.375							10						
	.437							12						
	.500							14						
	.562				Length Tolerance			16		Length Tolerance				
	.625				± .010			20		± 0.25				
	.750							24						
	.875							26						
	1.000							30						
	1.250							35						
	1.500							40						
	1.750							45						
2.000							50							

Notes:

- Please consult SPIROL Engineering for recommended hole sizes when used as a press-fit.
- Other diameters and lengths available on request.
- Series FH100 is available to order with a round head.

Part Number Code

TO ORDER: SLDP (Nominal Diameter)x(Length)(Material)(Finish)(Pin Series Number)

EXAMPLE: SLDP 4 x 16 FK FH100

SPIROL MATERIALS AND FINISHES

STANDARD MATERIALS

Low Carbon Steel (F)

Low carbon steel is one of the most versatile materials available. This material is readily available, and is the most economical of the standard Solid Pin materials in the absence of any plating or coating. Low carbon Solid Pins have a dry to the touch rust preventative. Additional coatings and finishes can be applied to carbon steel to improve corrosion resistance, however for some applications, it may be more appropriate and cost beneficial to specify stainless steel when a high level of corrosion resistance is required.

Austenitic (Nickel) Stainless Steel (D)

Austenitic stainless steel provides excellent corrosion protection against normal environmental conditions. It withstands fresh water and atmospheric marine conditions very well, and is suitable for many other industrial conditions including acidic environments. All austenitic stainless Solid Pins are passivated.

STANDARD FINISHES

Plain/Oiled (K)

This finish is a thin coating of dry-to-the touch oil that provides corrosion resistance during storage and shipping. Since this lubricating oil is suspended in a carrier which evaporates over time, the pins are dry-to-the-touch and conducive for automatic feeding and assembly.

Passivated (P)

Passivation of stainless steel Solid Pins is a process whereby surface contaminants such as embedded tool steel and other free iron particles are removed. The sole purpose of passivation is to remove embedded iron; not to clean the part. While all stainless steel Solid Pins are passivated as a standard, there are some critical applications that absolutely require passivation such as medical devices, components used in the food or drug industry, fuel system applications, and any application requiring a clean environment.

Available only for stainless steel.

MATERIALS		FINISHES
TYPE	GRADE	
F - Low Carbon Steel	UNS G10220 / C20C (1.0411)	K - Plain, oiled
D - Stainless Steel, Austenitic (Nickel)	UNS S30500 / X4CrNi18-12	P - Passivated

SPECIAL MATERIALS

SPIROL has extensive experience with special materials required for unique circumstances such as:

Alloy Steel (W)

Alloy steel is used for applications requiring higher shear strength than our standard materials provide, or when additional hardness is required to ensure that the pin is harder than the host material into which the pin is being installed.

Aluminum (A)

Aluminum is lightweight, lead free, and has sufficient strength for most plastic applications. Aluminum is less than half the weight of steel, and does not require any supplemental coatings or platings to provide the necessary corrosion protection in most environments.

Other materials and finishes are available to order depending on the application requirements.



Technical Centers

Americas

SPIROL International Corporation
30 Rock Avenue
Danielson, Connecticut 06239 U.S.A.
Tel. +1 860 774 8571
Fax. +1 860 774 2048

SPIROL Shim Division
321 Remington Road
Stow, Ohio 44224 U.S.A.
Tel. +1 330 920 3655
Fax. +1 330 920 3659

SPIROL Canada
3103 St. Etienne Boulevard
Windsor, Ontario N8W 5B1 Canada
Tel. +1 519 974 3334
Fax. +1 519 974 6550

SPIROL Mexico
Avenida Avante #250
Parque Industrial Avante Apodaca
Apodaca, N.L. 66607 Mexico
Tel. +52 81 8385 4390
Fax. +52 81 8385 4391

SPIROL Brazil
Rua Mafalda Barnabé Soliane, 134
Comercial Vitória Martini, Distrito Industrial
CEP 13347-610, Indaiatuba, SP, Brazil
Tel. +55 19 3936 2701
Fax. +55 19 3936 7121

Europe

SPIROL France
Cité de l'Automobile ZAC Croix Blandin
18 Rue Léna Bernstein
51100 Reims, France
Tel. +33 3 26 36 31 42
Fax. +33 3 26 09 19 76

SPIROL United Kingdom
17 Princewood Road
Corby, Northants
NN17 4ET United Kingdom
Tel. +44 1536 444800
Fax. +44 1536 203415

SPIROL Germany
Ottostr. 4
80333 Munich, Germany
Tel. +49 89 4 111 905 71
Fax. +49 89 4 111 905 72

SPIROL Spain
08940 Cornellà de Llobregat
Barcelona, Spain
Tel. +34 93 669 31 78
Fax. +34 93 193 25 43

SPIROL Czech Republic
Sokola Tůmy 743/16
Ostrava-Mariánské Hory 70900
Czech Republic
Tel/Fax. +420 417 537 979

SPIROL Poland
ul. Solec 38 lok. 10
00-394, Warszawa, Poland
Tel. +48 510 039 345

Asia Pacific

SPIROL Asia Headquarters
1st Floor, Building 22, Plot D9, District D
No. 122 HeDan Road
Wai Gao Qiao Free Trade Zone
Shanghai, China 200131
Tel. +86 21 5046 1451
Fax. +86 21 5046 1540

SPIROL Korea
160-5 Seokchon-Dong
Songpa-gu, Seoul, 138-844, Korea
Tel. +86 (0) 21 5046-1451
Fax. +86 (0) 21 5046-1540

e-mail: info@spirol.com

Please refer to www.SPIROL.com for current specifications and standard product offerings.

SPIROL Application Engineers will review your application needs and work with you to recommend the optimum solution. One way to start the process is to visit our **Optimal Application Engineering** portal at **SPIROL.com**.