

Measurement Techniques for the Inspection of Series 550 Coiled Pins for Cosmetic Cases

by Ian Martin, Quality Manager
SPIROL Industries Ltd.

SPIROL® Series 550 Cosmetic Coiled Pins were designed specifically to be used as hinge pins in cosmetic cases. The seam of this extra light duty Coiled Pin is 'tucked' or rolled to ensure the pin remains round. In addition, the seam is prepared with a beveled edge to soften the transition into the 'comma' area (see Figure 1). A key characteristic of a Coiled Pin is that the diameter of the pin at the seam is equal to or less than the diameter adjacent to the seam. This prevents the edge of the material from contacting the inside diameter of the hole wall and prevents skiving when inserted. Once installed, the 1½ coil formation exerts the ideal amount of radial force to provide self-retention as well as the desired swing torque without damaging the plastic. Considering that the pin is a functional spring, it will absorb shock and vibration, isolating the plastic from excessive force that could open up the hole. The result is exceptional performance and preservation of the desired fit and function throughout the life of the product. These factors combine to make the **SPIROL® Series 550 Cosmetic Coiled Pin** ideal for hinges in cosmetic cases.

Diameter Measurement

Diameter is measured utilizing a spline type micrometer (Fig. 2a) with reduced measuring faces. Standard micrometers (Fig. 2b) are too large and do not lend themselves to measuring such tiny parts. It is also highly recommended that a binocular magnifier/optivisor (Fig. 3) is used to ensure correct orientation of parts is achieved during inspection.

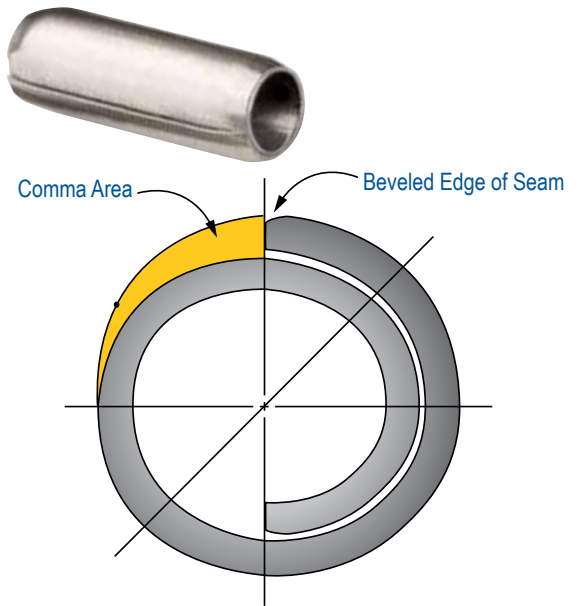

Figure 1. The Coiled Pin's seam is prepared with a beveled edge to soften the transition into the 'comma' area. This design feature ensures that there are no "high spots" at the seam.



Figure 2a. Spline type micrometer with reduced measuring face



Figure 2b. Standard Micrometer

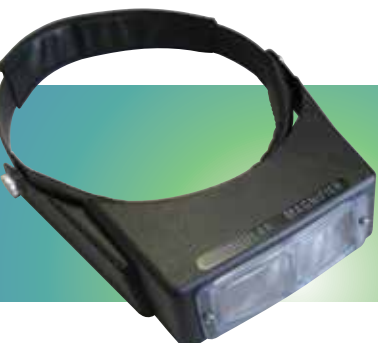
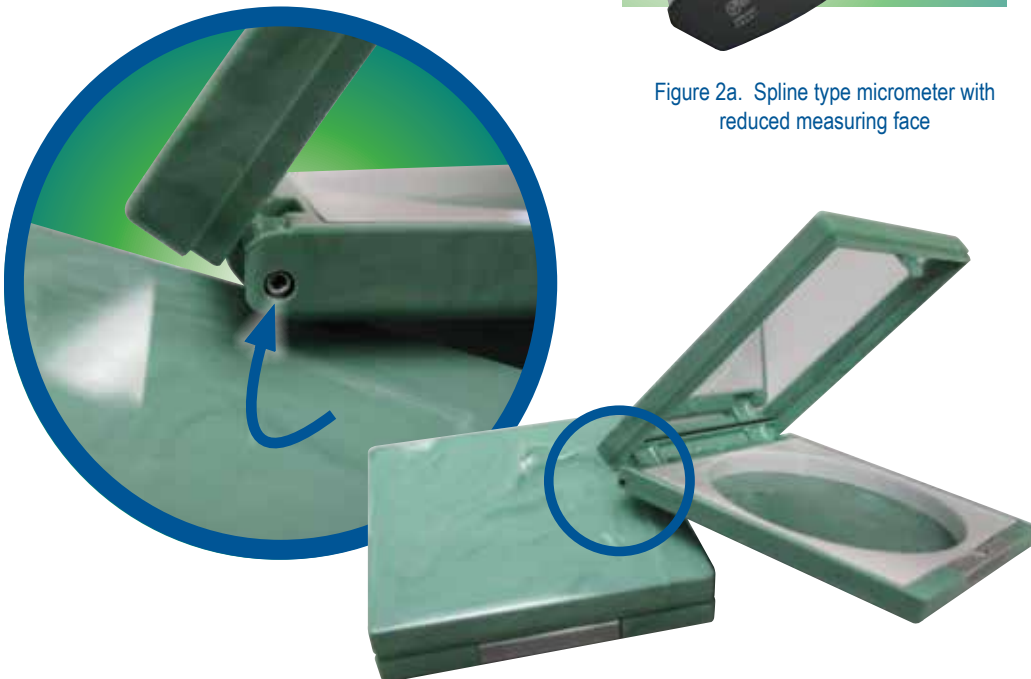

Figure 3. Binocular Magnifier/Optivisor

Diameter Measurement (continued)

The Coiled Pin will be within specification over 270° of the outer circumference. Micrometer measurements are taken at 0°, 45°, and 90° to the seam as depicted in the diagrams below (Fig. 4). It is critical that the pin be centered between the upper and lower anvils and that the micrometer not be tightened beyond the point at which it contacts the pin. **The tiniest amount of excess compression will yield an incorrect reading.** Diameter is to be measured a minimum of one pin diameter in length from the end of the pin. This eliminates measurement error relating to the transition from chamfer to tenon diameter. For example, when measuring a Ø1.2 mm Coiled Pin, diameter would be measured no closer than 1.2 mm to the end of the pin.

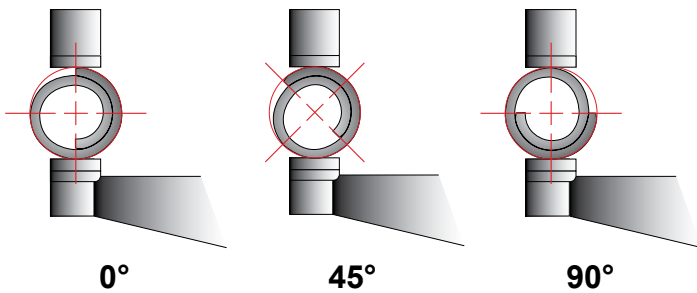

Figure 4. Micrometer measurements.

The use of a micrometer stand will (Fig. 5) make it easier for the inspector to correctly locate the pin between the micrometer anvils and ensure no excessive pressure is applied during measuring. Hold the pin between the thumb and forefinger in the correctly orientated position and gently wind down the micrometer spindle until the anvils make contact with the pin.

Extreme care has to be taken while performing the inspection due to the extreme flexibility of the pin. Unlike when measuring more rigid components, contact with the pin should be determined more through sight using the optivisor (or other type of magnifying lens) and the initial feel of the pin between thumb and forefinger rather than feel of the micrometer spindle tightening onto the pin. If the micrometer can be felt “tightening down” onto the pin after the initial contact, it has been over-tightened and the reading will be false.



Figure 5. Micrometer in Micrometer Stand

Length Measurement

The length of a Coiled Pin is easily measured utilizing calipers. It is critical that the pin be positioned squarely between the anvils of the measuring tool. See the photographs below:

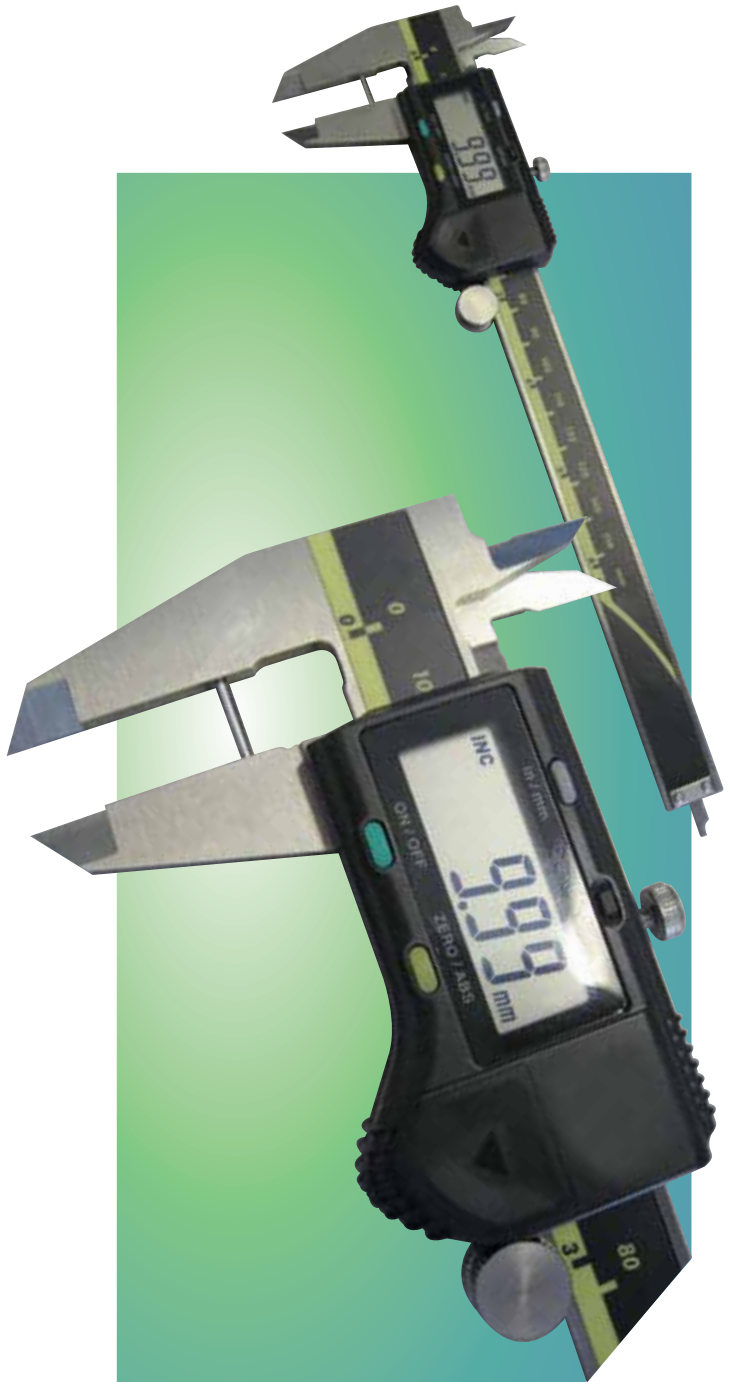

Chamfer Diameter ('B' Max)

The chamfer diameter or "B" (below) is designed to be smaller than the minimum recommended hole to facilitate insertion. This feature should be measured with an optical comparator. The easiest method by which to inspect the chamfer diameter is to either lay the pin horizontally in a v-block (Fig. 6a) or mount the pin vertically in modeling clay or plumbers putty (Fig. 6b) for support. Place the pin and mounting device on the comparator stage. If using the v-block, locate the y axis of the projection screen crosshair on the extreme edge of the chamfer. If using modeling clay, locate the x axis of the projection screen crosshair on the extreme edge of the chamfer. Zero the measuring mechanism before relocating the crosshair to the opposite edge of the chamfer. This will yield the chamfer diameter.

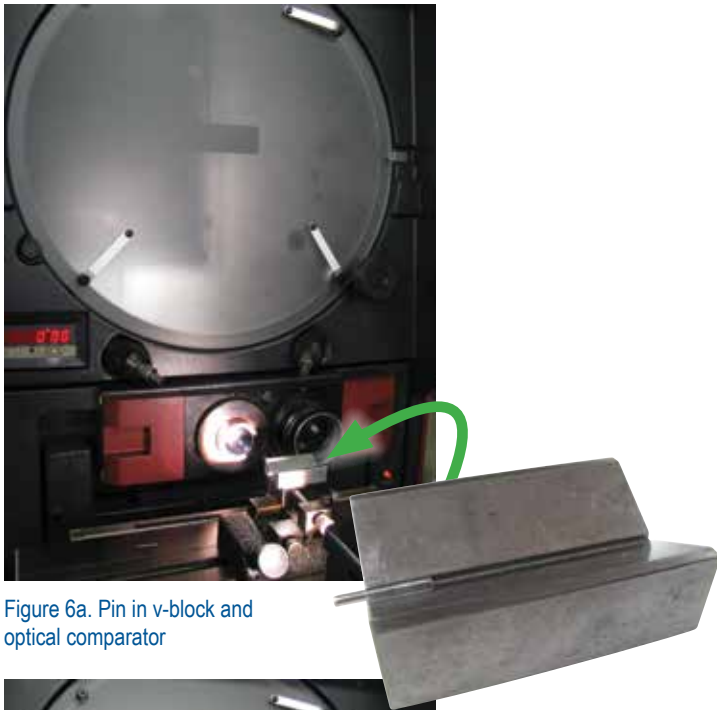

Figure 6a. Pin in v-block and optical comparator

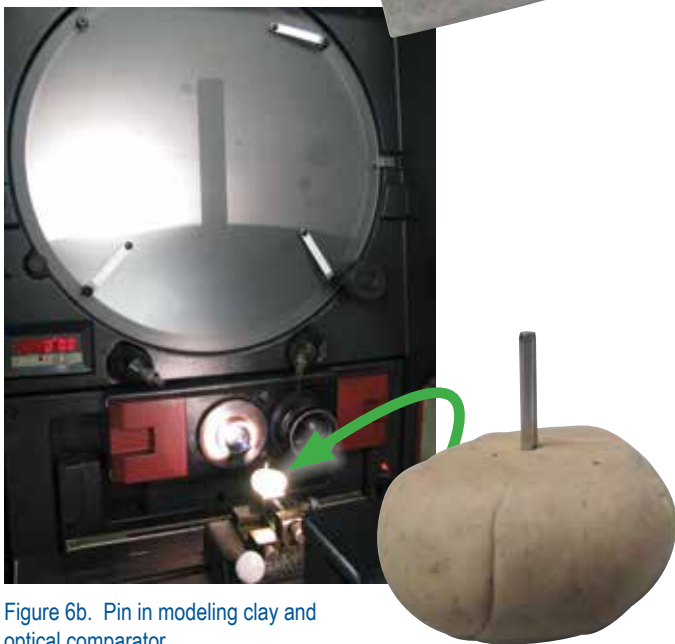

Figure 6b. Pin in modeling clay and optical comparator

Design Guidelines for Cosmetic Cases

SPIROL Series 550 Cosmetic Pins



The use of a **Series 550 Cosmetic Coiled Pin** will simplify design as misalignment of the inner and outer holes to provide friction is no longer necessary. Intentional misalignment is difficult to control in production and induces stress in the hinge area causing cracking and pin fallout. Below are some guidelines that should be followed when designing cosmetic cases:

Ideally, all of the holes in the cover and base would be sized identically.

- If it is not possible to have identical hole sizes in the cover and the base, the tolerance may be divided between the outer and inner holes as follows:
 - Outer holes = Smaller half of tolerance
 - Inner holes = Larger half of tolerance
- Misalignment should not exceed 0.05 mm.
- 60% or more pin length retained by the inner boss.
- Minimum bearing surface in either boss should exceed three times the diameter of the pin.
- The inner boss hole depth should be at least 0.38 mm deeper than the retained pin length to prevent breaks at assembly.
- The minimum boss diameter should be two to three times the diameter of the pin to ensure adequate wall thickness.

SPIROL Model HC Horizontal, Dual Pin Inserter

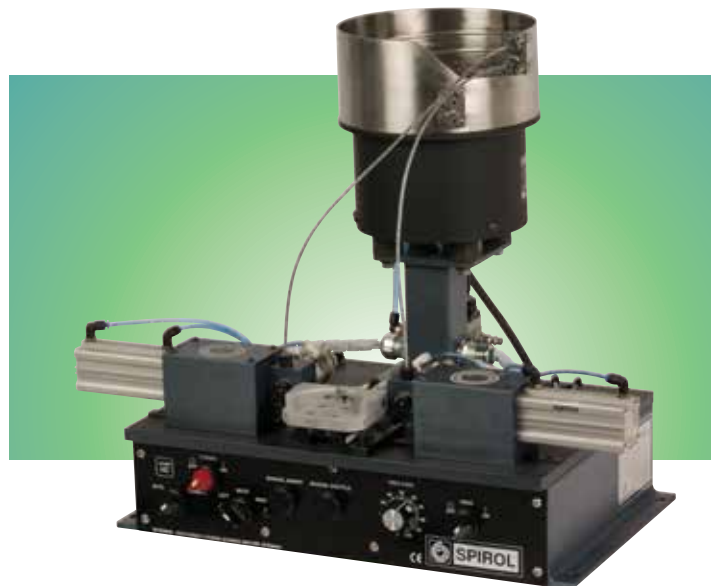

Designed to install **SPIROL** Series 550 Coiled Pins into plastic hinges.

SPIROL®

Innovative fastening solutions.
Lower assembly costs.



Please refer to www.SPIROL.com for current specifications and standard product offerings.

SPIROL Application Engineers will review your application needs and work with you to recommend the optimum solution. One way to start the process is to visit our **Optimal Application Engineering** portal at **SPIROL.com**.

© 2017 SPIROL International Corporation
No part of this publication may be reproduced or transmitted in any form or by any means, electronically or mechanically, except as permitted by law, without written permission from SPIROL International Corporation.

Technical Centers

Americas

SPIROL International Corporation
30 Rock Avenue
Danielson, Connecticut 06239 U.S.A.
Tel. +1 860 774 8571
Fax. +1 860 774 2048

SPIROL Shim Division
321 Remington Road
Stow, Ohio 44224 U.S.A.
Tel. +1 330 920 3655
Fax. +1 330 920 3659

SPIROL Canada
3103 St. Etienne Boulevard
Windsor, Ontario N8W 5B1 Canada
Tel. +1 519 974 3334
Fax. +1 519 974 6550

SPIROL Mexico
Carretera a Laredo KM 16.5 Interior E
Col. Moisés Saenz
Apodaca, N.L. 66613 Mexico
Tel. +52 81 8385 4390
Fax. +52 81 8385 4391

SPIROL Brazil
Rua Mafalda Barnabé Soliane, 134
Comercial Vitória Martini, Distrito Industrial
CEP 13347-610, Indaiatuba, SP, Brazil
Tel. +55 19 3936 2701
Fax. +55 19 3936 7121

Europe

SPIROL France
Cité de l'Automobile ZAC Croix Blandin
18 Rue Léna Bernstein
51100 Reims, France
Tel. +33 3 26 36 31 42
Fax. +33 3 26 09 19 76

SPIROL United Kingdom
17 Princewood Road
Corby, Northants
NN17 4ET United Kingdom
Tel. +44 1536 444800
Fax. +44 1536 203415

SPIROL Germany
Ottostr. 4
80333 Munich, Germany
Tel. +49 89 4 111 905 71
Fax. +49 89 4 111 905 72

SPIROL Spain
08940 Cornellà de Llobregat
Barcelona, Spain
Tel. +34 93 193 05 32
Fax. +34 93 193 25 43

SPIROL Czech Republic
Sokola Tümy 743/16
Ostrava-Mariánské Hory 70900
Czech Republic
Tel/Fax. +420 417 537 979

SPIROL Poland
ul. M. Skłodowskiej-Curie 7E / 2
56-400, Oleśnica, Poland
Tel. +48 71 399 44 55

Asia Pacific

SPIROL Asia Headquarters
1st Floor, Building 22, Plot D9, District D
No. 122 HeDan Road
Wai Gao Qiao Free Trade Zone
Shanghai, China 200131
Tel. +86 21 5046 1451
Fax. +86 21 5046 1540

SPIROL Korea
160-5 Seokchon-Dong
Songpa-gu, Seoul, 138-844, Korea
Tel. +86 (0) 21 5046-1451
Fax. +86 (0) 21 5046-1540

e-mail: info@spirol.com

SPIROL.com